

# GLOBE<sup>®</sup>

## YOUR GLOBAL FORCE IN FLUID POWER

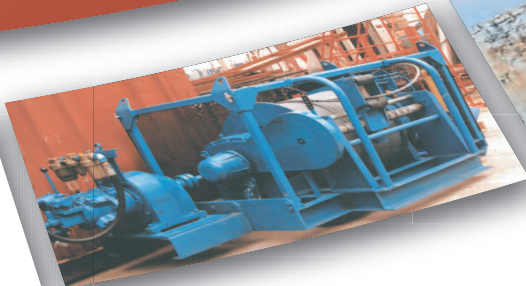

# **GLOBE<sup>®</sup>** Radial Piston Air Motors

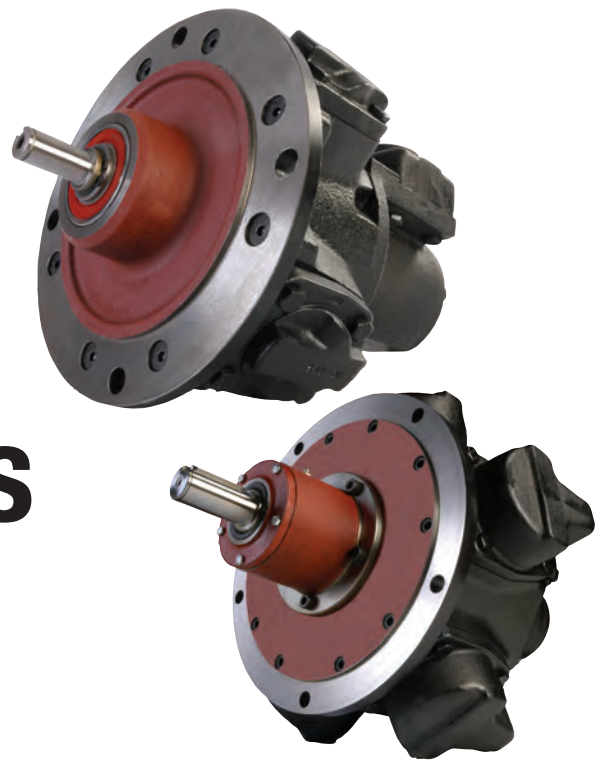

### Applications:

Globe Air Motors offer a series of compact heavy duty radial piston air motors offering exceptional range of control valve and output options.

The Air Motors consist of four or five radial pistons with oil bath lubrication developing greater power than other motors of equivalent size.

Globe Radial Piston Air Motors (RM) range from 1.7 KW to 23 KW.

WINCHES  
PAPER & PULP MILLS  
STEEL MILLS  
CONSTRUCTION  
OIL & GAS INDUSTRIES  
OFFSHORE MARINE  
SHIPYARDS  
MIXERS & PUMPS  
CONVEYORS  
MINES  
HOISTS  
TRACK DRIVES

- **Continuous or Intermittent Operation**
- **Temperature range:**  
-20°C to +80°C
- **Consideration:**
  - **Running Torque (Power Only)**
  - **Starting Torque where the motor starts under load**

# The Unique Benefits of GLOBE Air Motors

- Modular motor, brake, gearbox and control valve options.
- Relatively inexpensive variable speed control.
- Intrinsically safe in hazardous environments (e.g. petrol-chemical, mines, oil & gas etc.)
- Instantly reversible.
- Resistant to dirty, damp conditions.
- Positive start.
- Rugged design.
- NEMA and S.A.E. interfaces:
  - RM210, RM310, RM410, RM510 and RM610 motors can be supplied in configurations approximating to NEMA interfaces.
  - RM410, RM510 and RM610 motors are also available with S.A E. drives.
- ATEX & Non-ATEX gearboxes available.
- RM motors are most suitable for heavy duty applications and can be supplied direct coupled to gearboxes.
- Natural sweet gas & other gases can also be used. Contact Factory for details
- For complete range of gearboxes, Contact Factory for options.
- Variety of mountings.

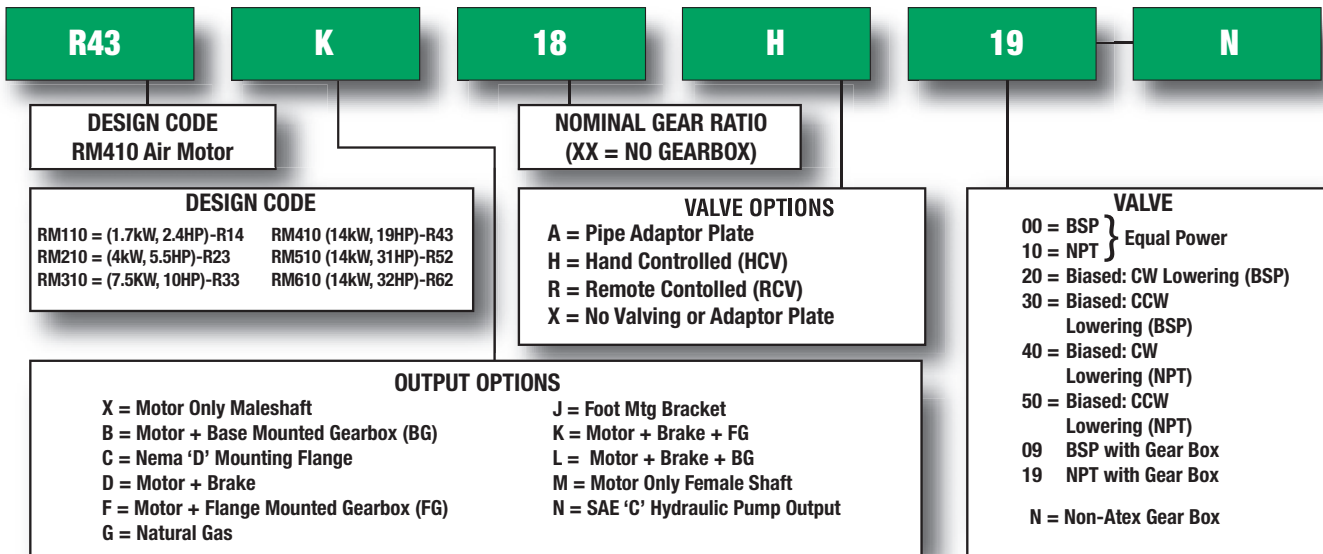

DIRECTIONAL VALVES FOR VARIABLE SPEED

EXAMPLE: R43K18H19N  
RM410 motor with brake, flange mounted 18:1 gearbox and hand controlled valve with NPT ports, non-ATEX gearbox

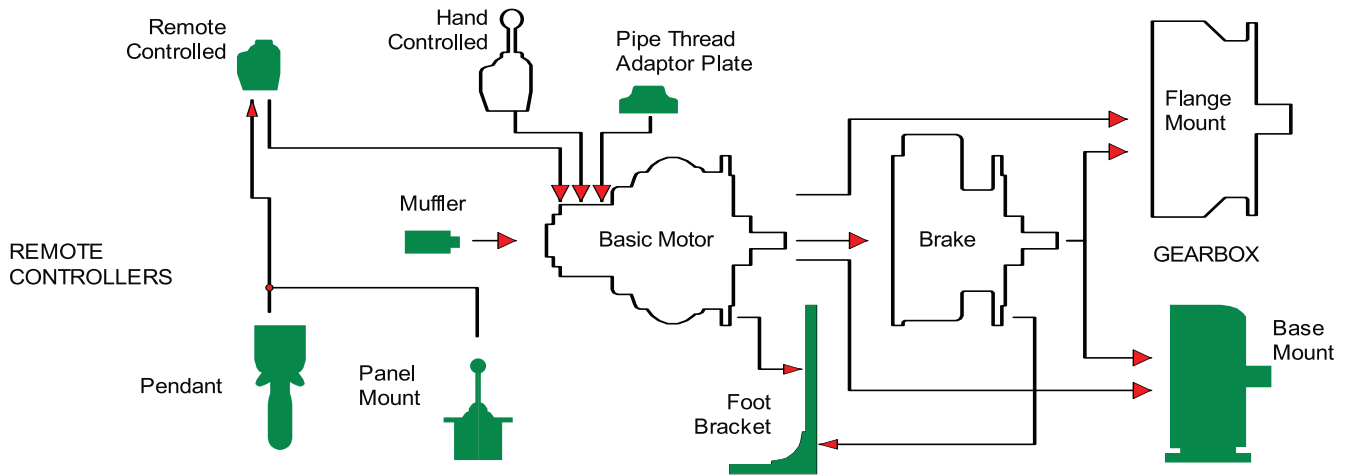

**GLOBE**

United States  
5885 11th Street  
Rockford, Illinois 61109  
Tel: (800) 541-1418  
Fax: (800) 288-7031  
Email : info@globeairmotors.com  
[www.globeairmotors.com](http://www.globeairmotors.com)

**YOUR GLOBE DISTRIBUTOR near you:**